

# Agilent 34970A Data Acquisition/Switch Unit

Product Overview

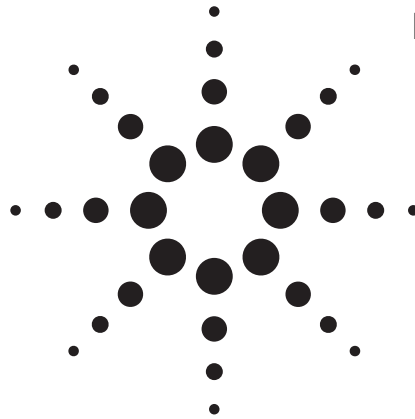

**Agilent performance  
at a fraction of the cost  
of other standalone  
data acquisition systems**



## Table of Contents

4	Features
6	Using the 34970A for data logging applications
7	Data Logging Feature Checklist
8	Using the 34970A for ATE applications
9	ATE Feature Checklist
10	Using the 34970A for switching applications
11	Customize your 34970A with plug-in modules
11	Modules-at-a-Glance Selection Guide
12	Agilent Quality
13	Spec Interpretation Guide
14	Accuracy Specifications
16	System Specifications
16	Software
17	Modules Specifications
18	Multiplexers (34901A, 34902A, and 34908A)
20	Actuator module (34903A)
20	Matrix module (34904A)
21	RF Multiplexer modules (34905A, 34906A)
22	Multifunction module (34907A)
23	Rack Mounting and Dimensions
24	Ordering Information

## Price and performance beyond compare

Go ahead and compare the Agilent Technologies 34970A Data Acquisition/Switch Unit with other data acquisition systems currently available. You'll find it hard to come up with a system that offers the powerful measurement performance, flexibility, and ease of use of the 34970A—even in systems costing three to five times as much.

How did we manage to pack so much performance into such a low-cost instrument? We borrowed technology developed for our top-of-the-line products and put it into a package that cuts assembly time, incorporates custom ICs to reduce parts count, and simplifies production testing. That means it costs us less to make. The results? You spend less without sacrificing quality or performance.

## What can you expect from a data acquisition system that's this affordable?

### Measurements you-can trust

We took the measurement engine from our best-selling benchtop DMM and embedded it inside a 3-slot cardcage. You get the benefit of proven Agilent measurement performance, universal inputs with built-in signal conditioning, and modular flexibility, all in a low-cost, compact data acquisition package. The 34970A features 6½ digits (22 bits) of resolution, 0.004% basic dcV accuracy, and ultra-low reading noise. Combine that with scan rates of up to 250 channels/sec, and you've got the speed and accuracy you need to get the job done right the first time.

## Powerful flexibility-to get-your job done

Whether you need to measure temperature, ac/dc volts, resistance, frequency, or current, the 34970A can handle it. The internal autoranging DMM directly measures 11 different functions, eliminating the need for expensive external signal conditioning. And our unique design allows complete per-channel configurability for maximum flexibility and quick, easy set up. It's-like having an independent, high-performance DMM behind each channel.

## Custom configurations that-grow with you

Three module slots and eight switch/control modules allow you to customize the 34970A to meet your unique requirements. Buy only what you need—and add more modules later as your application grows.

## Unequaled ease of use

From the simplified configuration procedures, to the self-guiding front panel interface, we put in extra time and energy to save yours. Simple things like on-module screw-terminal connectors, built-in thermocouple reference junctions, well-organized user documentation full of examples and hints, and a standard Getting Started kit that will have you making measurements 15 minutes out of the box all add up to increased productivity, whether you use the instrument every day or only now and then.

## Free software to-save you time-and money

Now you don't have to spend your valuable time writing or configuring software. Agilent BenchLink Data Logger 3 software gives you a familiar Microsoft Windows® interface for test configuration and real-time data display and analysis. Even better, the data logging application is included with every standard Agilent 34970A.



**More power and flexibility  
than you ever imagined you could afford**

Intuitive front panel: task-oriented,  
self-guiding menus

6½-digit (22-bit) internal  
DMM measures 11 functions without  
external signal conditioning

50k readings of non-volatile  
memory holds data when  
power is removed

Monitor display  
mode lets you  
keep an eye on  
tests in progress

Scaling function for  
converting raw inputs  
into user-defined units

HI/LO alarm limits on each input  
channel, plus 4 TTL alarm outputs

Battery-backed real-time clock-for pacing  
scans and timestamping readings

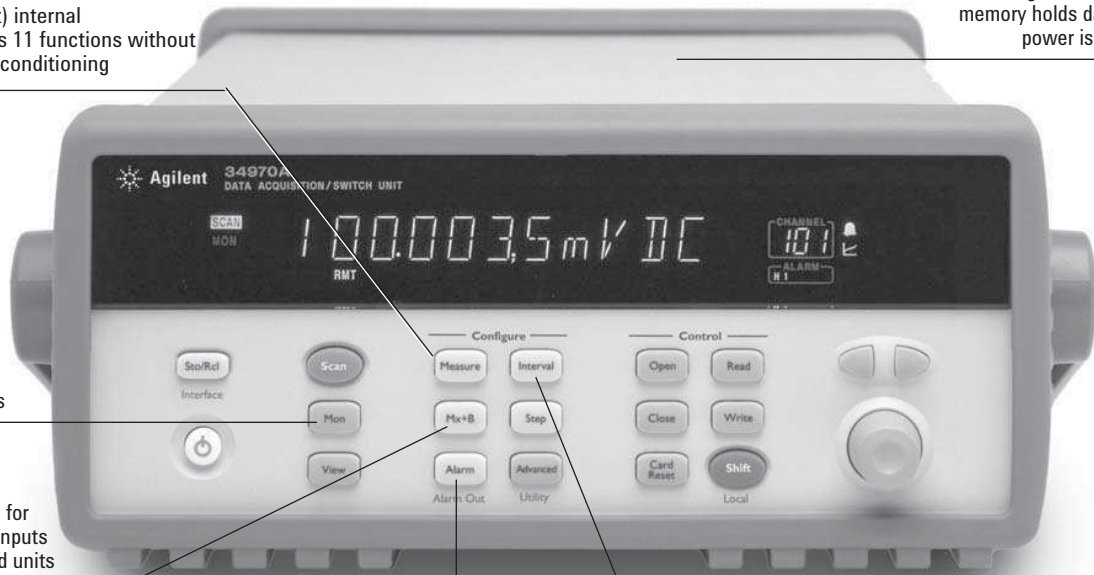

3-slot mainframe  
offers up to 96 matrix crosspoints or  
120 single-ended channels

*Agilent BenchLink Data Logger 3  
software included;  
drivers available for Agilent VEE and  
National Instruments LabVIEW*

8 switch and control  
plug-in modules to  
choose from

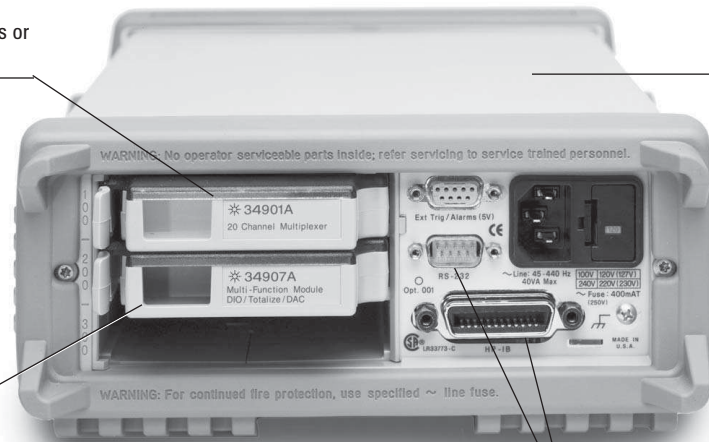

Built-in GPIB and RS-232 interfaces

## The Agilent 34970A offers unequalled-versatility for your data acquisition applications

In the past, you had to make a choice. On the one hand, you could choose the simple operation and low cost of a data logger. On the other hand, you had the flexibility and higher performance of a modular data acquisition system. The Agilent 34970A Data Acquisition/Switch Unit gives you the best of both worlds: a simple user interface with low per-channel cost, modular flexibility, and impressive measurement performance.

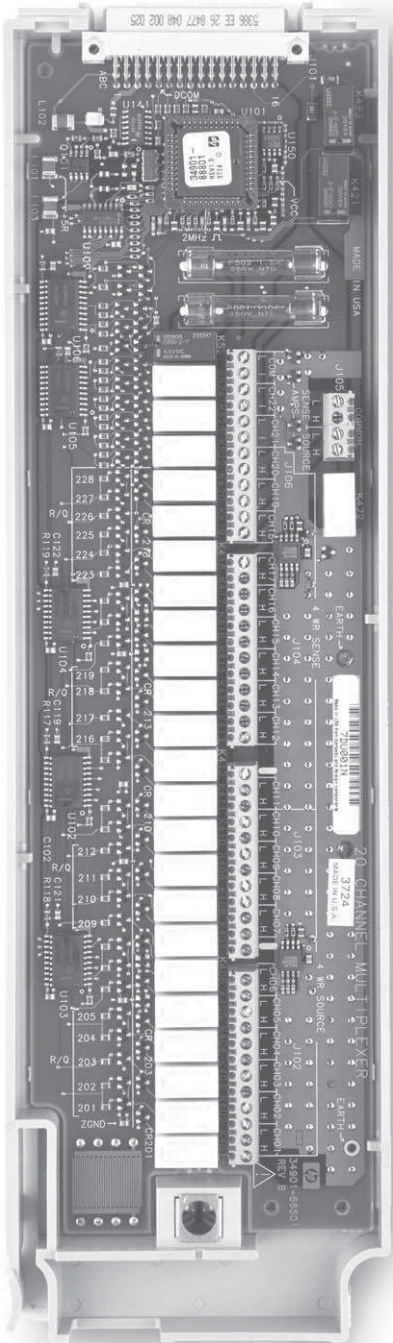

Whether you're an R&D engineer working on characterizing your latest design, or a manufacturing engineer building a test system or troubleshooting a process, the 34970A Data Acquisition/Switch Unit offers the best combination of price and measurement performance.

### It's a data-logger:

Configured with a 20-channel relay multiplexer, the 34970A becomes a powerful, low-cost data logger for simple characterization applications—one that's quick to set up and easy to run. For more information on using the 34970A for data logging applications, see page 6.

### It's a data acquisition front-end:

The 34970A is an automated test system with excellent measurement performance—it's got the accuracy, resolution, and speed you need. See page 8 for application information.

### It's a switch system:

Order the mainframe without the internal DMM and you've got an even lower cost, high-quality signal routing solution. See-page 10 for details.



## An easy-to-use data logger for-monitoring and characterization applications

Data loggers are used to monitor multiple signals (temperature, voltage, etc.) over extended periods of time to identify irregularities. Example applications include environmental chamber monitoring, component inspection, benchtop testing, process troubleshooting, and temperature profiling.

The Agilent 34970A is easy to use for a-multipitude of data logging and monitoring applications, either stand-alone or with a computer. Its-flexible, modular design makes it-scalable from 20 to 120 channels, and lets you add actuator, digital I/O, and analog output channels for simple control. Its small size and ruggedized features make it perfect for portable applications, and its small footprint makes it ideal for cramped benchtop testing. Standard GPIB (IEEE 488) and RS-232 interfaces let you program the instrument if you wish to automate tests.

## Better measurements with-fewer hassles

Tired of putting up with the mediocre measurement performance you get with most data loggers or plug-in data acquisition boards? The 34970A offers 6½ digits of resolution and 0.004% basic 1-year dcV accuracy.

### Simplify your data gathering-with Agilent-BenchLink Data-Logger 3 software

Do you want PC-based data logging capability, but don't want to spend hours programming? The BenchLink Data Logger 3 software is the answer. This Windows-based application is designed to make it a snap to use your PC for gathering and analyzing measurements. Use it to set up your test, acquire and archive measurement data, and perform real-time display and analysis of the incoming measurements.

A familiar spreadsheet environment makes it easy to configure and control your tests. And a rich set of colorful graphics provides many options for analyzing and displaying your data—all with point-and-click ease. Set up multiple graphics using strip charts, histograms, bar and scatter charts, individual channel results, and more. And of course you can use BenchLink Data Logger 3 to easily move data to other applications for further analysis, or for inclusion in your presentations and reports.

Channel	Enable Channel	Name	Scan	Monitor	Function	Range	Res	Adv	Scale	Unit	Label	Test	High	Low	Holdtime
101 Channel	<input checked="" type="checkbox"/>	Enter Name	<input type="checkbox"/>	<input type="checkbox"/>	DC Vrms	100V	0.5	Select	1	0 VDC	Off	0	0	None	
102 Channel	<input type="checkbox"/>	Enter Name	<input type="checkbox"/>	<input type="checkbox"/>	Frequency	100V	45	Select	1	0 Hz	Off	0	0	None	
103 Channel	<input type="checkbox"/>	Enter Name	<input type="checkbox"/>	<input type="checkbox"/>	DC Vrms	Auto	5.5	Select	1	0 VDC	Off	0	0	Select	
104 Channel	<input type="checkbox"/>	Enter Name	<input type="checkbox"/>	<input type="checkbox"/>	DC Vrms	Auto	5.5	Select	1	0 VDC	Off	0	0	Select	
105 Channel	<input type="checkbox"/>	Enter Name	<input type="checkbox"/>	<input type="checkbox"/>	DC Vrms	Auto	5.5	Select	1	0 VDC	Off	0	0	Select	
106 Channel	<input type="checkbox"/>	Enter Name	<input type="checkbox"/>	<input type="checkbox"/>	DC Vrms	Auto	5.5	Select	1	0 VDC	Off	0	0	Select	
107 Channel	<input type="checkbox"/>	Enter Name	<input type="checkbox"/>	<input type="checkbox"/>	DC Vrms	Auto	5.5	Select	1	0 VDC	Off	0	0	Select	
108 Channel	<input type="checkbox"/>	Enter Name	<input type="checkbox"/>	<input type="checkbox"/>	DC Vrms	Auto	5.5	Select	1	0 VDC	Off	0	0	Select	
109 Channel	<input type="checkbox"/>	Enter Name	<input type="checkbox"/>	<input type="checkbox"/>	DC Vrms	Auto	5.5	Select	1	0 VDC	Off	0	0	Select	
110 Channel	<input type="checkbox"/>	Enter Name	<input type="checkbox"/>	<input type="checkbox"/>	DC Vrms	Auto	5.5	Select	1	0 VDC	Off	0	0	Select	
111 Channel	<input type="checkbox"/>	Enter Name	<input type="checkbox"/>	<input type="checkbox"/>	DC Vrms	Auto	5.5	Select	1	0 VDC	Off	0	0	Select	
112 Channel	<input type="checkbox"/>	Enter Name	<input type="checkbox"/>	<input type="checkbox"/>	DC Vrms	Auto	5.5	Select	1	0 VDC	Off	0	0	Select	
113 Channel	<input type="checkbox"/>	Enter Name	<input type="checkbox"/>	<input type="checkbox"/>	DC Vrms	Auto	5.5	Select	1	0 VDC	Off	0	0	Select	
114 Channel	<input type="checkbox"/>	Enter Name	<input type="checkbox"/>	<input type="checkbox"/>	DC Vrms	Auto	5.5	Select	1	0 VDC	Off	0	0	Select	
115 Channel	<input type="checkbox"/>	Enter Name	<input type="checkbox"/>	<input type="checkbox"/>	DC Vrms	Auto	5.5	Select	1	0 VDC	Off	0	0	Select	
116 Channel	<input type="checkbox"/>	Enter Name	<input type="checkbox"/>	<input type="checkbox"/>	DC Vrms	Auto	5.5	Select	1	0 VDC	Off	0	0	Select	
117 Channel	<input type="checkbox"/>	Enter Name	<input type="checkbox"/>	<input type="checkbox"/>	DC Vrms	Auto	5.5	Select	1	0 VDC	Off	0	0	Select	
118 Channel	<input type="checkbox"/>	Enter Name	<input type="checkbox"/>	<input type="checkbox"/>	DC Vrms	Auto	5.5	Select	1	0 VDC	Off	0	0	Select	
119 Channel	<input type="checkbox"/>	Enter Name	<input type="checkbox"/>	<input type="checkbox"/>	DC Vrms	Auto	5.5	Select	1	0 VDC	Off	0	0	Select	
120 Channel	<input type="checkbox"/>	Enter Name	<input type="checkbox"/>	<input type="checkbox"/>	DC current	Auto	5.5	Select	1	0 ADC	Off	0	0	Select	
121 Channel	<input type="checkbox"/>	Enter Name	<input type="checkbox"/>	<input type="checkbox"/>	DC current	Auto	5.5	Select	1	0 ADC	Off	0	0	Select	
122 Channel	<input type="checkbox"/>	Enter Name	<input type="checkbox"/>	<input type="checkbox"/>	DC current	Auto	5.5	Select	1	0 ADC	Off	0	0	Select	

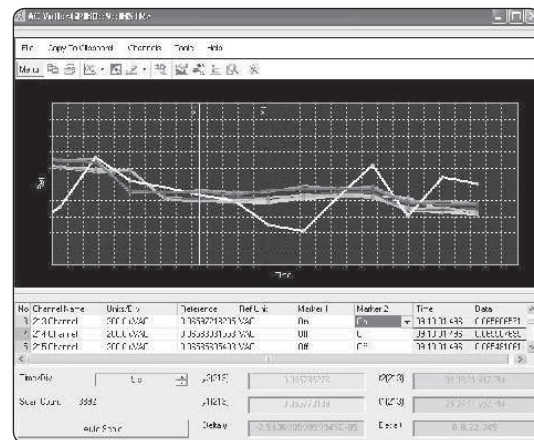

And the 34970A measures and converts 11 different input signals:

- temperature with thermocouples, RTDs, and thermistors
- dc and ac volts
- 2- and 4-wire resistance
- frequency and period
- dc and ac current

What's more, each channel is independently configurable. This means you can configure channel 1 for dcV, channel 2 for a K-type thermocouple, and channels 3 and 13 for a 4-wire RTD measurement— all on the same module, all in a single scan. For custom linear conversions, use the Mx+B scaling function on any channel. You can even display a custom 3-character engineering label like RPM or PSI to identify your measurement units.

### Versatile alarms

Alarms are available on a per-channel basis as well. Enter a high limit, a low limit, or both. The 34970A compares each reading to its limits and flags any out-of-range measurements. You can assign one of four TTL alarm outputs to any input channel to trigger external alarm lights, sirens, or send a TTL pulse to your control system, all without a PC connected.

### Scanning made-simple

The 34970A automatically builds-a scan list that includes all configured inputs (even digital inputs from the Agilent 34907A multifunction module) in ascending order by channel number. You can pace scans by setting the 34970A's internal timer for automatic scanning at a specific interval, by manually pressing a front-panel button, or by sending a software command or external TTL trigger pulse.

### Monitor any input

A special display mode monitors a-selected input channel, continuously updating the display with new readings—even during a-scan. It's great for keeping an eye-on a key input, or for troubleshooting your system before-a test.

### Nonvolatile memory adds convenience, portability

All readings are automatically time-stamped and stored in a nonvolatile 50,000-reading memory—enough memory to hold more than a week's worth of data (20 channels scanned every five minutes). The-nonvolatile memory holds your data even after power is removed, so you can use the 34970A to collect data at a remote location for later uploading to a PC. And because the nonvolatile memory also holds your system configuration, if you lose power in the middle of a test, the 34970A resumes scanning when power is returned.

#### Data Logging Feature Checklist

- From 1 to 120 channels of analog input
- Measurements include dc volts, ac volts, thermocouple, thermistor and RTD temperature measurements, 2- and 4-wire Ohms, dc current, ac current, frequency, and period
- 6½ digits (22 bits) of resolution with 0.004% basic 1-year dcV accuracy
- 50k reading nonvolatile memory including timestamp
- Scaling and alarms available on each channel
- Full-featured front panel for stand-alone configuration, troubleshooting, and data viewing
- BenchLink Data Logger 3 software for configuration and data analysis
- Nonvolatile storage for five complete instrument states

## **A powerful, flexible data acquisition system for automated-test**

The 34970A gives you the resolution, accuracy, repeatability, and speed you've come to expect from an Agilent data acquisition system. It provides the measurement muscle you need, along with signal routing and control capability, in a flexible, modular format that can grow and change to match your varied applications.

### **Powerful measurements**

The internal 6½-digit DMM brings the power and performance of a world-class stand-alone DMM to the 34970A, but at a fraction of the cost and in a fraction of the space. It's as accurate as the best bench DMM available: 0.004% basic 1-year dcV accuracy, 0.06% basic 1-year acV accuracy, and 0.01% basic 1-year resistance accuracy. Our patented Multi-slope III A-D technology offers incredible linearity (2 ppm of reading +1 ppm of range) along with 22 bits of real resolution. And since it is an integrating A/D, it provides excellent noise rejection as well—a nice change from noisy PC plug-ins and sampling A/Ds. No more averaging lots of samples just to see the real data you wanted. And-if you need high scan rates, the 34970A is capable of delivering fully converted measurements at speeds up to 250-ch/s.

The input section of the DMM is optically isolated and shielded from the 34970A's earth-referenced circuitry and computer interface, offering up to 300 V of input isolation. This is important for reducing ground loop and common mode voltage errors associated with long wiring runs and floating measurement sources.

### **Flexible functionality**

The DMM is installed inside the chassis rather than in one of the slots, leaving all three mainframe slots free for switch and control modules. You can choose from eight different modules (see page 11) to get the precise functionality you need now—while giving you flexibility for future expansion.

The internal DMM gives you the flexibility to measure 11 types of inputs easily and inexpensively. The-built-in signal conditioning and conversion routines turn raw inputs directly into real information. Each-measurement channel is independently configurable, so you can set different measurement functions, scale factors and alarm limits, even on adjacent channels. Advanced measurement features such as offset compensation, variable integration time, and delay are also selectable on a per-channel basis.

### **Get better measurements with built-in signal conditioning**

The Agilent 34970A architecture offers advantages over other data acquisition solutions which rely on external or plug-in signal conditioning modules for handling functions other than dcV:

- Minimizes external wiring and the resultant potential for noise and errors to enter your system
- Reduces hidden costs and overall system cost by avoiding unnecessary cables, breakout boxes and signal conditioning elements
- Simplifies your configuration—for faster, easier setup—with fewer connections and components
- Takes the guesswork out of error analysis. Measurement accuracies are specified to include all system-related errors
- Improves reliability, with fewer interconnects and fewer parts that-can fail



### Software drivers

Your months of test system software development time need not go to waste. Software drivers that support Agilent VEE and National Instruments LabView® are available for the 34970A to make integration into your test system easy. Standard RS-232 and GPIB interfaces and SCPI programming language make integration even easier.

### ATE Feature Checklist

- 3-slot cardcage with 6½ digit (22 bit) internal DMM
- 0.004% basic 1-year dcV accuracy; 0.06% acV accuracy
- Up to 120 single-ended measurements or 96 matrix crosspoints in a 3½" high, half-rack instrument
- Eight switch and control modules include low-frequency and RF-multiplexers, matrix and actuation switches, digital input and output, analog output, and event recording
- Scan rates up to 250 ch/s
- GPIB and 115 kbaud RS-232 interfaces standard
- Software drivers available to support Agilent VEE and National-Instruments LabView
- Relay maintenance feature for system maintenance



Compact 60-channel data acquisition system

## Low-cost, high-quality switching for automated test

If you don't need the built-in measurement capability of the 34970A, save money by ordering it without the DMM. What you end up with is the lowest-cost switch unit on the market. It's an ideal solution for routing test signals to and from your DUT and assorted instruments, including external DMMs, scopes, counters, and power supplies. Plus, you can add the DMM later if your needs change.

### The functionality you need

We put a lot of thought into defining and designing the modules for the 34970A in order to cover a broad spectrum of switching and signal routing requirements with fewer modules. The result? Simplified ordering and easier configuration.

And while we were at it, we improved performance and density. The 34970A modules can switch from microvolts to 300-volts, dc to 2-GHz, and with densities as high as 120 single-ended channels or 96 matrix crosspoints per frame. Plus, simple control capabilities like analog outputs, open collector digital outputs, and isolated Form-C-relays for controlling higher-powered devices are available.

### Easy scanning

The 34970A can easily scan with external instruments. It builds a scan list that includes all enabled low-frequency multiplexer inputs. Scans are controlled with the external "channel advance" input, or with the front panel "Step" key.



Low-cost switching system for automated testing

## Customize your Agilent 34970A with-plug-in modules

A complete selection of plug-in modules gives you high-quality measurement, switching, and control capabilities to choose from. Modules include both low-frequency and RF multiplexers, a matrix switch, a general-purpose switch, and a multifunction module that includes digital input/output, analog output, and totalizer capabilities. You can mix and match modules to get just the functionality you need right now—then change or add more channels later as your application grows.

Modules for the 34970A are designed to make your testing easier, faster, and more reliable. Here's how:

### Higher throughput

Our unique architecture incorporates a high-performance microprocessor on each module, off-loading the mainframe processor and minimizing backplane communications for faster throughput.

### More channels in less space

Surface mount construction and a highly integrated design minimize the space required for relay drive and interface circuitry. High density on-module connectors save both board and connector space normally required by a terminal block. We use the latest technology to squeeze the most out of the remaining board space, giving you up to 40 single-ended channels in roughly the same space used by many data acquisition system terminal blocks.

### Convenient connections

On-module screw-terminal connectors make wiring more convenient. Built-in strain-relief cable routing and cable tie points keep your wiring secure and safe from accidental tugs and pulls. An internal analog bus routes signals from any of the low-frequency multiplexers directly to the internal DMM, without the need for external connections.

Use the chart below to help you pinpoint the modules that meet your needs.

## Agilent Modules-at-a-Glance Selection Guide

Model Description	Type	Speed (ch/sec)	Max Volts	Max Amps	Bandwidth	Thermal Offset	Comments	Page
<b>34901A</b> 20 ch Multiplexer	2-wire armature (4-wire selectable)	60	300 V	1A	10 MHz	< 3 $\mu$ V	Built-in cold junction reference 2 additional current channels (22 total)	18
<b>34902A</b> 16 ch Multiplexer	2-wire reed (4-wire selectable)	250	300 V	50 mA	10 MHz	< 6 $\mu$ V	Built-in cold junction reference	19
<b>34903A</b> 20 ch Actuator/GP Switch	SPDT/form C	120	300 V	1A	10 MHz	< 3 $\mu$ V		20
<b>34904A</b> 4 x 8 Matrix	2-wire armature	120	300 V	1A	10 MHz	< 3 $\mu$ V		20
<b>34905A</b> Dual 4 ch RF Mux 50 $\Omega$	Common Low (unterminated)	60	42 V	0.7 A	2 GHz	< 6 $\mu$ V	1 GHz bandwidth through BNC-to-SMB adapter cable	21
<b>34906A</b> Dual 4 ch RF Mux 75 $\Omega$	Common Low (unterminated)	60	42 V	0.7 A	2 GHz	< 6 $\mu$ V	1 GHz bandwidth through BNC-to-SMB adapter cable	21
<b>34907A</b> Multifunction Module	Two 8-bit digital I/O ports 26-bit Event Counter Two 16-bit Analog outputs		42 V 42 V $\pm$ 12 V	400 mA 10 mA	100 KHz dc		Open drain Selectable input threshold Max 40 mA total output per frame	22
<b>34908A</b> 40 ch Single-Ended Mux	1-wire armature (common low)	60	300 V	1A	10 MHz	< 3 $\mu$ V	Built-in cold junction reference No four-wire measurements	19

## Agilent Quality

We know you can't afford instrument downtime due to hardware failures and unscheduled maintenance. That's why our engineers designed reliability into the 34970A: A rugged enclosure, state-of-the-art surface mount construction throughout, reduced parts counts, and rigorous and thorough testing on all aspects of the product.

## Take the guesswork out of relay maintenance

The 34970A uses our proprietary relay maintenance system to help you to predict relay end-of-life and avoid costly production-line downtime. It automatically counts every individual switch closure and stores it in nonvolatile memory on each module. You can query the total number of cycles on any individual channel so you can schedule maintenance and avoid erratic end-of-life failures.

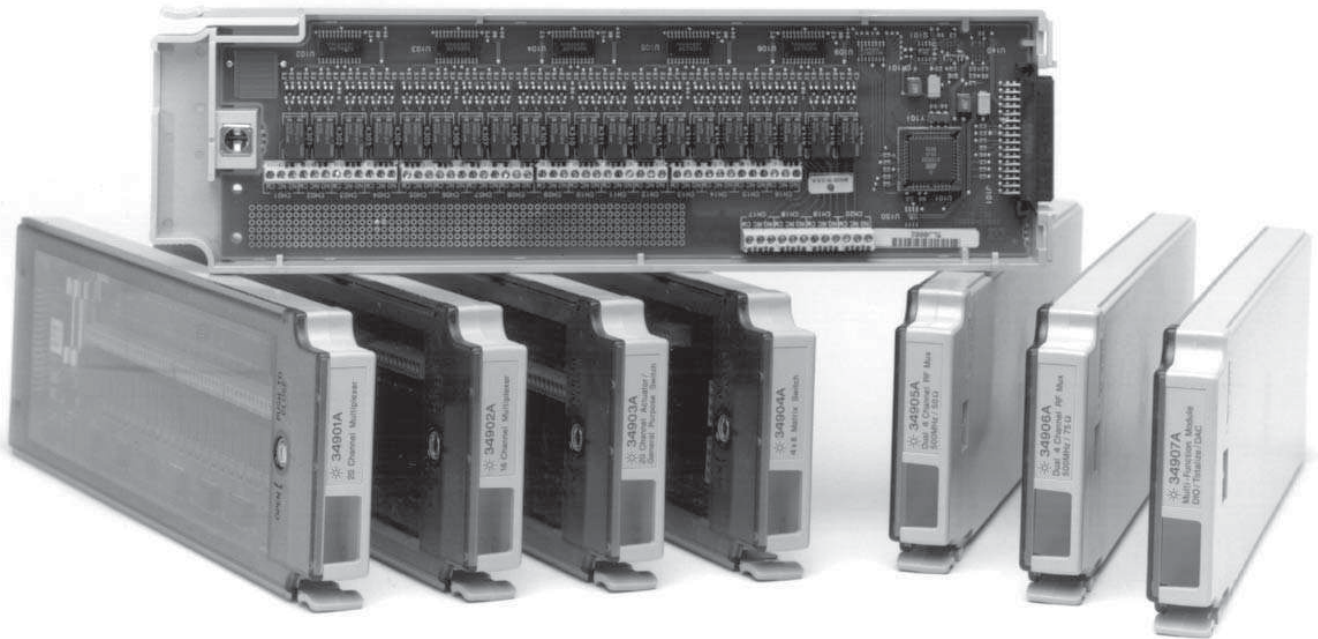



## Spec Interpretation Guide

The following pages list the technical specifications for the Agilent-34970A Data Acquisition/Switch Unit and its modules. The explanations and examples below are helpful in understanding how to interpret these specifications:

- Measurement accuracy is specified as percent of reading plus percent of range, where reading is the actual measured value and range is the name of the scale (1V, 10V, etc.)—not the full scale value (1.2V, 12V, etc.).
- DMM measurement accuracies include all switching errors. Switching errors are also listed separately in the module specifications section. Temperature measurement accuracies include ITS-90 conversion errors. The thermocouple accuracies include the reference junction error as well.
- Accuracies are listed as either 24-hour, 90-day, or 1-year specifications. This refers to the length of time since the instrument's last calibration. Use the specification that matches your calibration cycle. The 24-hour specifications are useful for determining short-term relative performance.

### EXAMPLE 1: Basic dcV accuracy

Calculate the accuracy of the following measurement:

9 V dc input  
10 V dc range  
1-year accuracy specifications  
Normal operating temperature (18°C–28°C)

From the following page, the 1-year accuracy is:  
0.0035% of reading + 0.0005% of range

Which translates into:  
 $(0.0035/100 \times 9 \text{ V}) +$   
 $(0.0005/100 \times 10 \text{ V}) = 365 \mu\text{V}$

For a total accuracy of:  
 **$365 \mu\text{V} / 9 \text{ V} = 0.0041\%$**

### EXAMPLE 2: Extreme operating temperature

When the 34970A is used outside of its 18°C–28°C temperature range, there are additional temperature drift errors to consider. Assume the same conditions in example 1, but at a 35°C operating temperature.

The basic accuracy is again:  
0.0035% of reading + 0.0005% of range = 365  $\mu\text{V}$ .

Now, multiply the 10 V temperature coefficient from the following page by the number of degrees outside of operating range for additional error:

$(0.0005\% \text{ reading} + 0.0001\% \text{ range})$

$/^\circ\text{C} \times (35^\circ\text{C} - 28^\circ\text{C}) =$

$(0.0005\% \text{ reading} + 0.0001\% \text{ range})$

$/^\circ\text{C} \times 7^\circ\text{C} =$

0.0035% reading + 0.0007% range = 385  $\mu\text{V}$

Total error is then:

**$365 \mu\text{V} + 385 \mu\text{V} = 750 \mu\text{V}$  or 0.008%**

### EXAMPLE 3: Thermocouple measurement accuracy

Calculating the total thermocouple reading error is easy with the 34970A—just add the listed measurement accuracy to the accuracy of your transducer. Switching, conversion, and reference junction errors are already included in the measurement specification.

For this example, assume a J-type thermocouple input reading 150°C.

From the following page, total error is:

Thermocouple probe accuracy + 1.0°C

The probe vendor specifies accuracy of 1.1°C or 0.4%, whichever is greater.

Total error is then:

**$1.0^\circ\text{C} + 1.1^\circ\text{C} = 2.1^\circ\text{C}$  total, or-1.4%**

### EXAMPLE 4: acV Accuracy

The acV function measures the true RMS value of the input waveform, regardless of waveshape. Listed accuracies assume a sinewave input. To adjust accuracies for non-sinusoids, use the listed crest factor adder.

For this example, assume a  $\pm 1$  V square wave input with 50% duty cycle and a 1 kHz frequency.

Accuracy for 1 V, 1 kHz sinusoid is:

0.06% reading + 0.04% range

A 50% duty cycle squarewave has a crest factor of

Peak Value / RMS value = 1 V / 1 V = 1

From Crest Factor table, add:

0.05% of reading

The total accuracy is:

**0.11% of reading + 0.04% of range = 1.5 mV or 0.15%**



## Accuracy Specifications $\pm$ (% of reading + % of range)<sup>[1]</sup>

Includes measurement error, switching error, and transducer conversion error

	Range <sup>[3]</sup>	Frequency, etc.	24 Hour <sup>[2]</sup> 23°C $\pm$ 1°C	90 Day 23°C $\pm$ 5°C	1 Year 23°C $\pm$ 5°C	Temperature Coefficient 0°C–18°C, 28°C–55°C
<b>DC Voltage</b>						
	100.0000 mV		0.0030 + 0.0035	0.0040 + 0.0040	0.0050 + 0.0040	0.0005 + 0.0005
	1.000000 V		0.0020 + 0.0006	0.0030 + 0.0007	0.0040 + 0.0007	0.0005 + 0.0001
	<b>10.00000 V</b>		<b>0.0015 + 0.0004</b>	<b>0.0020 + 0.0005</b>	<b>0.0035 + 0.0005</b>	<b>0.0005 + 0.0001</b>
	100.0000 V		0.0020 + 0.0006	0.0035 + 0.0006	0.0045 + 0.0006	0.0005 + 0.0001
	300.0000 V		0.0020 + 0.0020	0.0035 + 0.0030	0.0045 + 0.0030	0.0005 + 0.0003
<b>True RMS AC Voltage<sup>[4]</sup></b>						
	100.0000 mV to 100.0000V	3 Hz–5 Hz	1.00 + 0.03	1.00 + 0.04	1.00 + 0.04	0.100 + 0.004
		5 Hz–10 Hz	0.35 + 0.03	0.35 + 0.04	0.35 + 0.04	0.035 + 0.004
		<b>10 Hz–20 kHz</b>	<b>0.04 + 0.03</b>	<b>0.05 + 0.04</b>	<b>0.06 + 0.04</b>	<b>0.005 + 0.004</b>
		20 kHz–50 kHz	0.10 + 0.05	0.11 + 0.05	0.12 + 0.05	0.011 + 0.005
		50 kHz–100 kHz	0.55 + 0.08	0.60 + 0.08	0.60 + 0.08	0.060 + 0.008
		100 kHz–300 kHz <sup>[5]</sup>	4.00 + 0.50	4.00 + 0.50	4.00 + 0.50	0.20 + 0.02
	300.0000V	3 Hz–5 Hz	1.00 + 0.05	1.00 + 0.08	1.00 + 0.08	0.100 + 0.008
		5 Hz–10 Hz	0.35 + 0.05	0.35 + 0.08	0.35 + 0.08	0.035 + 0.008
		10 Hz–20 kHz	0.04 + 0.05	0.05 + 0.08	0.06 + 0.08	0.005 + 0.008
		20 kHz–50 kHz	0.10 + 0.10	0.11 + 0.12	0.12 + 0.12	0.011 + 0.012
		50 kHz–100 kHz	0.55 + 0.20	0.60 + 0.20	0.60 + 0.20	0.060 + 0.020
		100 kHz–300 kHz <sup>[5]</sup>	4.00 + 1.25	4.00 + 1.25	4.00 + 1.25	0.20 + 0.05
<b>Resistance<sup>[6]</sup></b>						
	100.0000	1 mA current source	0.0030 + 0.0035	0.008 + 0.004	0.010 + 0.004	0.0006 + 0.0005
	1.000000 k	1 mA	0.0020 + 0.0006	0.008 + 0.001	0.010 + 0.001	0.0006 + 0.0001
	<b>10.00000 k</b>	<b>100 <math>\mu</math>A</b>	<b>0.0020 + 0.0005</b>	<b>0.008 + 0.001</b>	<b>0.010 + 0.001</b>	<b>0.0006 + 0.0001</b>
	100.0000 k	10 $\mu$ A	0.0020 + 0.0005	0.008 + 0.001	0.010 + 0.001	0.0006 + 0.0001
	1.000000 M	5.0 $\mu$ A	0.002 + 0.001	0.008 + 0.001	0.010 + 0.001	0.0010 + 0.0002
	10.00000 M	500 nA	0.015 + 0.001	0.020 + 0.001	0.040 + 0.001	0.0030 + 0.0004
	100.0000 M	500 nA/10 M	0.300 + 0.010	0.800 + 0.010	0.800 + 0.010	0.1500 + 0.0002
<b>Frequency and Period<sup>[7]</sup></b>						
	100 mV to 300 V	3 Hz–5 Hz	0.10	0.10	0.10	0.005
		5 Hz–10 Hz	0.05	0.05	0.05	0.005
		10 Hz–40 Hz	0.03	0.03	0.03	0.001
		<b>40 Hz–300 kHz</b>	<b>0.006</b>	<b>0.01</b>	<b>0.01</b>	<b>0.001</b>
<b>DC Current (34901A only)</b>						
	10.00000 mA	<0.1 V burden	0.005 + 0.010	0.030 + 0.020	0.050 + 0.020	0.002 + 0.0020
	<b>100.0000 mA</b>	<b>&lt;0.6 V</b>	<b>0.010 + 0.004</b>	<b>0.030 + 0.005</b>	<b>0.050 + 0.005</b>	<b>0.002 + 0.0005</b>
	1.000000 A	<2 V	0.050 + 0.006	0.080 + 0.010	0.100 + 0.010	0.005 + 0.0010
<b>True RMS AC Current (34901A only)</b>						
	10.00000 mA and <sup>[4]</sup> 1.000000 A	3 Hz–5 Hz	1.00 + 0.04	1.00 + 0.04	1.00 + 0.04	0.100 + 0.006
		5 Hz–10 Hz	0.30 + 0.04	0.30 + 0.04	0.30 + 0.04	0.035 + 0.006
		<b>10 Hz–5 kHz</b>	<b>0.10 + 0.04</b>	<b>0.10 + 0.04</b>	<b>0.10 + 0.04</b>	<b>0.015 + 0.006</b>
	100.0000 mA <sup>[8]</sup>	3 Hz–5 Hz	1.00 + 0.5	1.00 + 0.5	1.00 + 0.5	0.100 + 0.06
		5 Hz–10 Hz	0.30 + 0.5	0.30 + 0.5	0.30 + 0.5	0.035 + 0.06
		10 Hz–5 kHz	0.10 + 0.5	0.10 + 0.5	0.10 + 0.5	0.015 + 0.06
<b>Temperature</b>						
	<b>Type</b>	<b>1-Year Accuracy<sup>[9]</sup></b>		<b>Extended Range 1-Year Accuracy<sup>[9]</sup></b>		
<b>Thermocouple<sup>[10]</sup></b>	B	1100°C to 1820°C	1.2°C	400°C to 1100°C	1.8°C	
	E	-150°C to 1000°C	1.0°C	-200°C to -150°C	1.5°C	
	<b>J</b>	<b>-150°C to 1200°C</b>	<b>1.0°C</b>	<b>-210°C to -150°C</b>	<b>1.2°C</b>	
	K	-100°C to 1200°C	1.0°C	-200°C to -100°C	1.5°C	0.03 °C
	N	-100°C to 1300°C	1.0°C	-200°C to -100°C	1.5°C	
	R	300°C to 1760°C	1.2°C	-50°C to 300°C	1.8°C	
	S	400°C to 1760°C	1.2°C	-50°C to 400°C	1.8°C	
	T	-100°C to 400°C	1.0°C	-200°C to -100°C	1.5°C	
<b>RTD</b>	R <sub>0</sub> from 49 $\Omega$ to 2.1 k $\Omega$	-200°C to 600°C	0.06°C			0.003 °C
<b>Thermistor</b>	2.2 k, 5k, 10k	-80°C to 150°C	0.08°C			0.002 °C

[1] Specifications are for 1 hr warm-up and 6½ digits, Slow ac filter

[2] Relative to calibration standards

[3] 20% over range on all ranges except 300 Vdc and ac ranges and 1 Adc and ac current ranges

[4] For sinewave input > 5% of range. For inputs from 1% to 5% of range and < 50 kHz, add 0.1% of range additional error

[5] Typically 30% of reading error at 1 MHz, limited to  $1 \times 10^8$  V Hz

[6] Specifications are for 4-wire ohms function or 2-wire ohms using Scaling to remove the offset. Without scaling, add 4  $\Omega$  additional error in 2-wire Ohms function

[7] Input > 100 mV. For 10 mV to 100 mV inputs multiply % of reading error x 10

[8] Specified only for inputs > 10 mA

[9] For total measurement accuracy, add temperature probe error

[10] Thermocouple specifications not guaranteed when 34907A module is present

## Measurement Characteristics<sup>[8]</sup>

### DC Voltage

Measurement Method	Continuously Integrating Multi-slope III A-D Converter
A-D Linearity	0.0002% of reading + 0.0001 % of range
Input Resistance	
100 mV, 1 V, 10 V ranges	Selectable 10 M $\Omega$ or > 10,000 M $\Omega$
100 V, 300 V ranges	10 M $\Omega$ $\pm$ 1%
Input Bias Current	< 30 pA at 25°C
Input Protection	300 V all ranges

### True RMS AC Voltage

Measurement Method	AC coupled True RMS — measures the AC component of the input with up to 300 Vdc of bias on any range
Crest Factor	Maximum of 5:1 at Full Scale
Additional Crest Factor	
Errors (non-sinewave)	Crest Factor 1-2   0.05 % of reading Crest Factor 2-3   0.15 % of reading Crest Factor 3-4   0.30 % of reading Crest Factor 4-5   0.40 % of reading
Input Impedance	1 M $\Omega$ $\pm$ 2% in parallel with 150 pF
Input Protection	300 Vrms all ranges

### Resistance

Measurement Method	Selectable 4-wire or 2-wire Ohms
	Current source referenced to LO input
Offset Compensation	Selectable on 100 $\Omega$ , 1k $\Omega$ , 10k $\Omega$ ranges
Maximum Lead Resistance	10% of range per lead for 100 $\Omega$ and 1 k $\Omega$ ranges. 1 k $\Omega$ on all other ranges
Input Protection	300 V on all ranges

### Frequency and Period

Measurement Method	Reciprocal counting technique
Voltage Ranges	Same as AC Voltage function
Gate Time	1s, 100 ms, or 10 ms
Measurement Timeout	Selectable 3 Hz, 20 Hz, 200 Hz LF limit

### DC Current

Shunt Resistance	5 $\Omega$ for 10 mA, 100 mA; 0.1 $\Omega$ for 1 A
Input Protection	1A 250 V fuse on 34901A module

### True RMS AC Current

Measurement Method	Direct coupled to the fuse and shunt. AC coupled True RMS measurement (measures the ac component only)
Shunt Resistance	5 $\Omega$ for 10 mA; 0.1 $\Omega$ for 100 mA, 1 A
Input Protection	1A 250 V fuse on 34901A module

### Thermocouple

Conversion	ITS-90 software compensation
Reference Junction Type	Internal, Fixed, or External
Open thermocouple Check	Selectable per channel. Open >5k $\Omega$

### Thermistor

44004, 44007, 44006 series

### RTD

$\alpha$  = 0.00385 (DIN) and  $\alpha$  = 0.00391

### Measurement Noise Rejection 60 (50) Hz<sup>[1]</sup>

dc CMRR	140 dB
ac CMRR	70 dB
<b>Integration Time</b>	<b>Normal Mode Rejection<sup>[2]</sup></b>
200 plc/3.33s (4s)	110 dB <sup>[3]</sup>
100 plc/1.67s (2s)	105 dB <sup>[3]</sup>
20 plc/333 ms (400 ms)	100 dB <sup>[3]</sup>
10 plc/167 ms (200 ms)	95 dB <sup>[3]</sup>
2 plc/33.3 ms (40 ms)	90 dB
1 plc/16.7 ms (20 ms)	60 dB
< 1 plc	0 dB

## Operating Characteristics<sup>[4]</sup>

### Single Channel Measurement Rates <sup>[5]</sup>

Function	Resolution <sup>[9]</sup>	reading/s
dcV, 2-wire Resistance	6 $\frac{1}{2}$ digits (10 plc)	6 (5)
	5 $\frac{1}{2}$ digits (1 plc)	57 (47)
	4 $\frac{1}{2}$ digits (0.02 plc)	490
Thermocouple	0.1°C (1 plc)	49 (47)
	(0.02 plc)	280
RTD, Thermistor	0.01°C (10 plc)	6 (5)
	0.1°C (1 plc)	47 (47)
	1°C (0.02 plc)	280
acV	6 $\frac{1}{2}$ Slow (3 Hz)	0.14
	6 $\frac{1}{2}$ Med (20 Hz)	1
	6 $\frac{1}{2}$ Fast (200 Hz)	8
	6 $\frac{1}{2}$ <sup>[6]</sup>	100
Frequency, Period	6 $\frac{1}{2}$ digits (1s gate)	1
	5 $\frac{1}{2}$ digits (100 ms)	9
	4 $\frac{1}{2}$ digits (10 ms)	70

### System Speeds <sup>[7]</sup>

INTO Memory	ch/s
single channel dcV	490
34902A scanning dcV	250
34907A scanning digital in	250
34902A scanning dcV with scaling & 1 alarm fail	220
34907A scanning totalize	170
34902A scanning temperature	160
34902A scanning acV <sup>[6]</sup>	100
34902A scanning dcV/Ohms on alternate channels	90
34901A/34908A scanning dcV	60
<b>INTO and OUT of memory to GPIB or RS-232 (init, fetch)</b>	
34902A scanning dcV	180
34902A scanning dcV with timestamp	150
<b>OUT of memory to GPIB<sup>[10]</sup></b>	
Readings	800
Readings with timestamp	450
Readings with all format options ON	310
<b>OUT of memory to RS-232</b>	
Readings	600
Readings with timestamp	320
Readings with all format options ON	230
<b>DIRECT to GPIB or RS-232</b>	
single channel dcV	440
34902A scanning dcV	200
single channel MEAS DCV 10 / MEAS DCV 1	25
single channel MEAS DCV/ MEAS OHMS	12

[1] For 1 K $\Omega$  unbalance in LO lead

[2] For power line frequency  $\pm$ 0.1%

[3] For power line frequency  $\pm$ 1% use 80 dB or  $\pm$ 3% use 60 dB

[4] Reading speeds for 60 Hz and (50 Hz) operation

[5] For fixed function and range, readings to memory, scaling and alarms off, AZERO OFF

[6] Maximum limit with default settling delays defeated

[7] Speeds are for 4 $\frac{1}{2}$  digits, delay 0, display off, autozero off.

Using 115 kbaud RS-232 setting

[8] Isolation voltage (ch - ch, ch - earth) 300 Vdc, ac rms

[9] 6 $\frac{1}{2}$  digits = 22 bits, 5 $\frac{1}{2}$  digits = 18 bits, 4 $\frac{1}{2}$  digits = 15 bits

[10] Assumes relative time format (time since start of scan)

## System Specifications

### Scanning Inputs

Analog	34901A, 34902A, and 34908A multiplexer channels
Digital	34907A digital in and totalize
Scan list	Scans channels in ascending order

### Scan Triggering

Source	Interval, external, button press, software, or on monitor channel alarm
Scan count	1 to 50,000 or continuous
Scan interval	0 to 99 hours; 1ms step size
Channel delay	0 to 60 seconds per channel; 1 ms step size
External trig delay	<300 $\mu$ s. With monitor on <200 ms
External trig jitter	<2 ms

### Alarms

Analog inputs	Hi, Lo, or Hi + Lo evaluated each scan
Digital inputs	34907A digital in maskable pattern match or state change 34907A totalize: Hi limit only
Monitor channel	Alarm evaluated each reading
Alarm Outputs	4 TTL compatible Selectable TTL logic Hi or Lo on fail
Latency	5 ms (typical)

### Memory

Readings	Battery backed, 4 year typical life <sup>[1]</sup> 50,000 with timestamp Readable during scan
States	5 instrument states with user label
Alarm Queue	Up to 20 events with channel number, reading, and timestamp

### System Features

Per-channel Math	Individual Mx + B scaling and Min/Max/Average calculated real time
Power Fail Recovery	Resumes scanning automatically
Relay maintenance	Counts each relay closure and stores on module User resettable
Real-time clock	Battery-backed, 4-year typical life <sup>[1]</sup>

### General Specifications

Power Supply	100V/120V/220V/240V $\pm$ 10%
Power Line Frequency	45 Hz to 66 Hz automatically sensed
Power Consumption	12 W (25 VA peak)
Operating Environment	Full accuracy for 0°C to 55°C Full accuracy to 80% R.H. at 40°C -40°C to 70°C <sup>[1]</sup>
Storage Environment	Net: 3.6 kg (8.0 lbs)
Weight	Conforms to CSA, UL-1244, IEC 1010 Cat I
Safety	CISPR 11, IEC 801/2/3/4
RFI and ESD	

## Software

### Agilent BenchLink Data Logger 3

(not included with Option 001)

### System Requirements<sup>[2]</sup>

Operating System	Windows 98SE, NT <sup>®</sup> 4.0 SP6a, 2000 SP4, XP SP2, Adobe <sup>®</sup> Acrobat <sup>®</sup> Reader V5.0 or higher (to view documentation) Microsoft <sup>®</sup> Internet Explorer V6.0 or higher (required when using Windows NT)
Controller	Recommend Pentium <sup>®</sup> 4, 800 MHz or greater, Min: Pentium III, 500 MHz
RAM	Recommend 256MB or greater, Min 128MB
Disk Space	Recommend 200MB, Min 100MB
Display	Recommend 800x600 resolution, 256 colors
<b>Computer Interfaces<sup>[3]</sup></b>	
GPIB	Agilent and National Instruments PCI-GPIB
LAN-to-GPIB	E5810A
USB-to-GPIB	82357A
	RS-232 (Serial Port) PC COM 1-4

### Agilent BenchLink Features

Configuration	Spreadsheet-like channel configurations page. Upload and Download instrument configurations. Computed channels using + - * /, dB, dBm, dBV, $x^2$ , $\sqrt{x}$ and full, $1/2$ , or $1/4$ bridge strain
Graphical Displays	Real-time and historical data displays Add, delete, size, and configure real time Strip chart with markers and alarm indication, bar and scatter charts, Histogram with statistics, Bar meter, and Data table
Graphical Controls	Sliders, switches, buttons, and LED lights
Alarm / Limit testing	Start/Stop scanning on alarm condition Control 34903A relay state or 34907A digital output on alarm
Data	Real time streamed (saved) to disk Automatically export data and configurations Copy data or graphics to windows clipboard Export your selected data to .CVS, .XML, or .TXT formats
Event logging	Automatic entry of alarms and errors

### Instrument Driver Support for Programming Languages

Universal Instrument Driver <sup>[5]</sup>	Compatible with Windows 95 and NT Agilent VEE 3.2 or greater Visual Basic 4.0, LabWindows CVI 4.0, LabVIEW 7.0
Labview Driver (VI)	LabVIEW 7.0

[1] Storage at temperatures above 40°C will decrease battery life

[2] Software provided on CD-ROM and includes utility to create floppy disks for installation

[3] Interface and driver must be purchased and installed separately

[4] 90 MHz Pentium, 20 MB RAM

[5] Requires VISA command library for IEEE-488

Microsoft, Windows, and Windows NT are U.S. registered trademarks of Microsoft Corporation.

Adobe and Acrobat are trademarks of Adobe Systems Incorporated.

Pentium is a U.S. registered trademark of Intel Corporation.

## Modules Specifications

The Agilent-34970A accuracy specifications already include the switching offset and reference junction errors shown below. These errors are listed separately for determining system error with external measurement devices.

Up to three modules, in any combination, can be inserted into a single mainframe. The 34970A's internal DMM connections are accessible only

through the 34901A, 34902A, and 34908A low-frequency multiplexers.

On-module screw terminals accept wire sizes from 16-gage to 22 gage. Twenty-gage wire is recommended for high channel count applications. The 34905A and 34906A RF Multiplexers use SMB connectors. A standard set of (10) BNC-to-SMB adapter cables is provided with each RF module for convenient BNC connections.

	Multiplexer			Actuator	Matrix	RF Multiplexer		Multifunction
	34901A	34902A <sup>[1]</sup>	34908A	34903A	34904A	34905A	34906A	34907A
<b>General</b>								
Number of Channels	20 + 2 2/4 wire	16 2/4 wire	40 1 wire	20 SPDT	4 x 8 2 wire	Dual 1 x 4 50Ω      75Ω		See page 22 for module specifications
Connects to Internal DMM	•	•	•					
Scanning Speed	60 ch/s	250 ch/s	60 ch/s					
Open/Close Speed	120/s	120/s	70/s	120/s	120/s	60/s		
<b>Input</b>								
Voltage (dc , ac rms) <sup>[2]</sup>	300 V	300 V	300 V	300 V	300 V	42 V		
Current (dc , ac rms)	1A	50mA	1A	1A	1A	0.7A		
Power (W , VA)	50 W	2 W	50 W	50 W	50 W	20 W		
<b>DC Characteristics</b>								
Offset Voltage <sup>[3]</sup>	< 3uV	< 6uV	< 3uV	< 3uV	< 3uV	< 6uV		
Initial Closed Channel R <sup>[3]</sup>	< 1Ω	< 1Ω	< 1Ω	< 0.2Ω	< 1Ω	< 0.5Ω		
Isolation ch-ch, ch-earth	> 10 GΩ	> 10 GΩ	> 10 GΩ	> 10 GΩ	> 10 GΩ	> 1 GΩ		
<b>AC Characteristics</b>								
Bandwidth <sup>[4]</sup>	10 MHz	10 MHz	10 MHz	10 MHz	10 MHz	2 GHz <sup>[5]</sup>	2 GHz <sup>[5]</sup>	
Insertion Loss (dB)	10 MHz	—	—	—	—	-0.1	-0.1	
	100 MHz	—	—	—	—	-0.4	-0.4	
	500 MHz	—	—	—	—	-0.6	-0.5	
	1 GHz	—	—	—	—	-1	-1	
	1.5 GHz	—	—	—	—	-1.2	-1.5	
	2 GHz	—	—	—	—	-3	-2	
SWR	10 MHz	—	—	—	—	1.02	1.02	
	100 MHz	—	—	—	—	1.05	1.05	
	500 MHz	—	—	—	—	1.20	1.25	
	1 GHz	—	—	—	—	1.20	1.40	
	1.5 GHz	—	—	—	—	1.30	1.40	
	2 GHz	—	—	—	—	1.40	2.00	
ch-ch Cross Talk (dB) <sup>[4]</sup>	10 MHz	-45	-45	-18 <sup>[6]</sup>	-45	-33	-100	-85
	100 MHz	—	—	—	—	—	-85	-75
	500 MHz	—	—	—	—	—	-65	-65
	1 GHz	—	—	—	—	—	-55	-50
	1.5 GHz	—	—	—	—	—	-45	-40
	2 GHz	—	—	—	—	—	-35	-35
Risetime							< 300 ps	
Signal Delay							< 3 ns	
Capacitance	HI - LO	< 50 pF	< 50 pF	< 50 pF	< 10 pF	< 50 pF	< 20 pF	
	LO - Earth	< 80 pF	< 80 pF	< 80 pF	< 80 pF	< 80 pF	—	
Volt-Hertz limit							10 <sup>10</sup>	
<b>Other</b>								
T/C Cold Junction Accuracy <sup>[3]</sup>	(typical)							
Switch Life	No Load (typical)	0.8°C	0.8°C	0.8°C <sup>[8]</sup>	100M	100M	5M	5M
	Rated Load (typical) <sup>[7]</sup>	100k	100k	100k	100k	100k	100k	100k
Temperature	Operating			all cards — 0°C to 55°C				
Humidity	Storage			all cards — -20°C to 70°C				
	(non-condensing)			all cards — 40°C/80% RH				

[1] Not recommended for connection to ac line without external transient suppression

[2] Channel-to-channel or channel-to-earth

[3] Errors included in DMM measurement accuracy specifications

[4] 50Ω source, 50Ω load

[5] Bandwidth direct to card SMB connectors

[6] Isolation within channel 1 to 20 or 21 to 40 banks is -40 dB

[7] Applies to resistive loads only

[8] Thermocouple measurements not recommended with 34908A module due to common lo configuration

## Multiplexer Selection-Guide

Choose between the broad functionality of the 34901A, the-high speed scanning of the 34902A, or the single-ended density of the 34908A. These three modules are the only way to connect to the 34970A internal DMM. They can be used to scan with external instruments as well.

All multiplexer modules employ break-before-make scanning, ensuring only one closed channel (or channel pair) at a time. Multiple channel closures are allowed on the 34901A and 34902A modules when not configured for scanning.

The 34908A does not allow multiple channel closures at any time.

	34901A	34902A	34908A
<b>Number of Channels</b>	20 + 2	16	40
<b>Max scan speed</b>	60 ch/s	250 ch/s	60 ch/s
<b>Number of contacts</b>	2 or 4	2 or 4	1

### Temperature

Thermocouple	•	•	•
2-wire RTD	•	•	•
4-wire RTD	•	•	•
Thermistor	•	•	•
dc Volts	•	•	•
ac Volts	•	•	•
2-wire Ohms	•	•	•
4-wire Ohms	•	•	•
Frequency	•	•	•
Period	•	•	•
dc current	•		
ac current	•		

## 34901A

### 20-Channel General-Purpose Multiplexer

- 60 ch/s scanning
- Two- and four-wire scanning
- Built-in thermocouple reference junction
- 300 V switching

The Agilent 34901A is the most versatile multiplexer for general purpose scanning. It combines dense, multifunction switching with 60-channel/second scan rates to address a broad spectrum of data acquisition applications.

Two- and four-wire channels can be-mixed on the same module. Two-additional fused inputs (22-channels total) route up to 1A-of-current to the internal DMM, allowing ac and dc current measurements without the need for external shunt resistors.

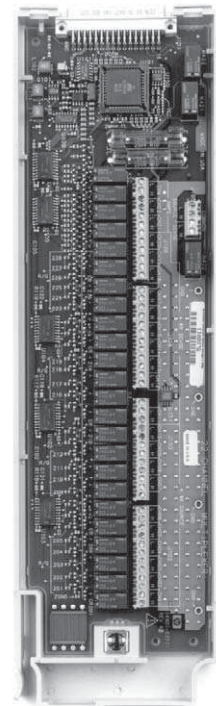
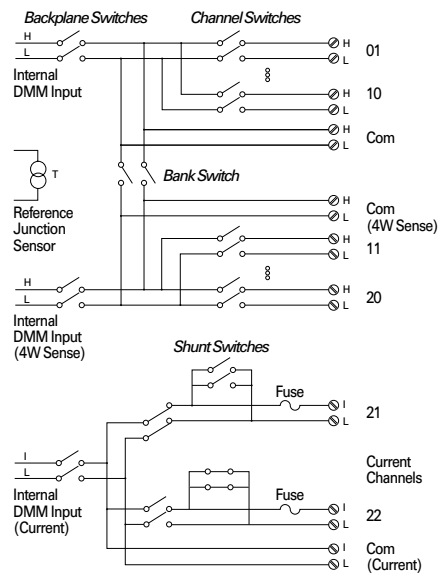



### 34902A

#### 16-Channel High-Speed Multiplexer

- 250 ch/s scanning
- Two- and four-wire scanning
- Built-in thermocouple reference junction

The Agilent 34902A employs reed relays-to achieve scan rates up to 250 channels per second. Use this module for high-throughput automated test applications as well-as high-speed data logging and monitoring tasks.

Sixteen two-wire inputs switch up to 300-V. Two- and four-wire channels may be mixed on the same module. User provided shunt resistors are required for current measurements.

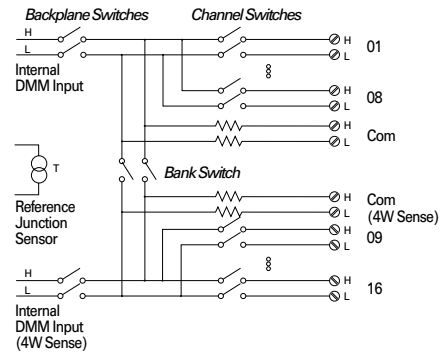

Note: Not recommended for connection to ac-line without external transient suppression.

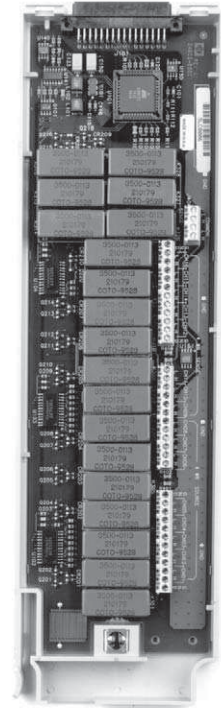

### 34908A

#### 40-Channel Single-Ended Multiplexer

- 60 ch/s scanning
- Single-wire switching for common-low applications
- Built-in thermocouple reference-junction

Use the Agilent 34908A for the greatest density in common-low applications, such as battery test, component characterization, and benchtop testing.

Each module switches 40 one-wire inputs. All two-wire internal measurements except current are supported. The module low connection is isolated from earth and can float up to 300 V.

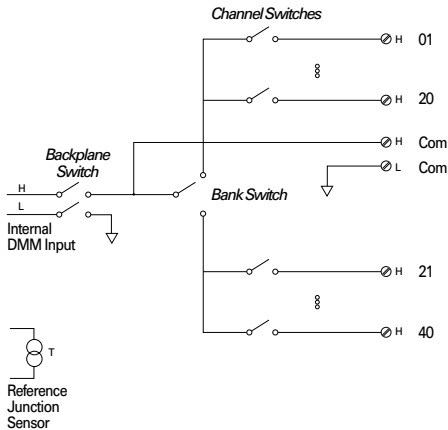

Note: Thermocouples must be electrically isolated from each other to avoid current loops and subsequent measurement errors.

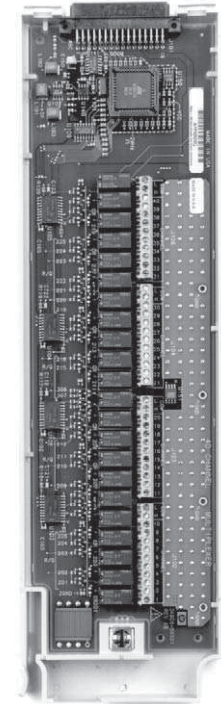

### 34903A

#### 20-Channel Actuator/General Purpose Switch

- SPDT (Form C) latching relays
- 300 V, 1A actuation and control

This general-purpose switch module has 20 independent single-pole, double-throw (SPDT) relays. Use it to cycle power to products under test, control indicator and status lights, and to actuate external power relays and solenoids. Combine it with matrix and multiplexer modules to build custom switch systems. Its 300 V, 1A contacts can handle up to 50 W, enough for many power line switching applications.

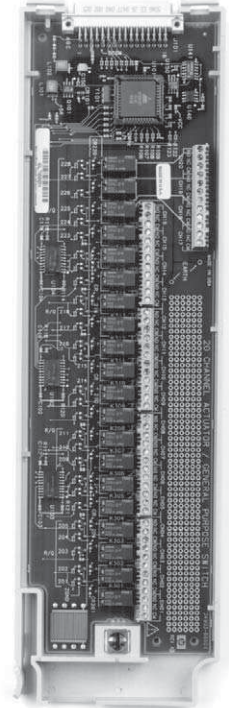
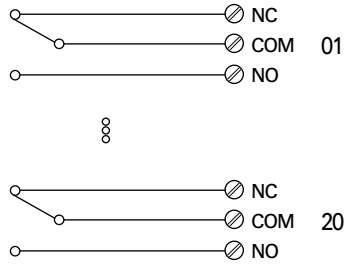

### 34904A

#### 4x8 Two-wire Matrix Switch

- 32 two-wire crosspoints
- 300 V, 1A switching

The Agilent 34904A gives you the most flexible connection path between your device under test and your test equipment, allowing different instruments to be connected to multiple points on your DUT at the same time.

Rows or columns may be connected between multiple modules to build 8x8, 4x16 or larger matrices, with up to 96 crosspoints in a single frame.

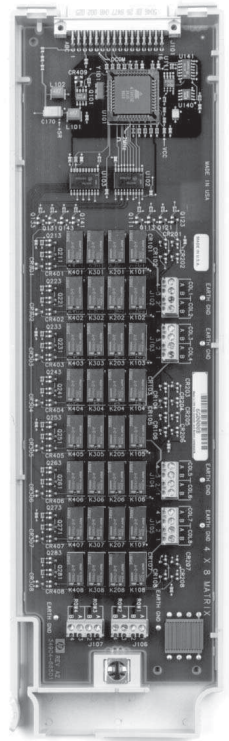
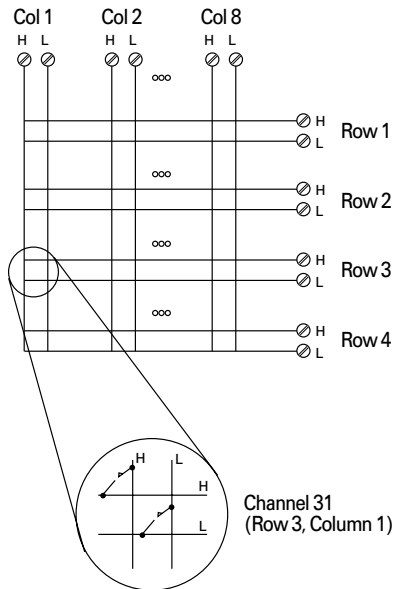

### 34905A 50Ω

### 34906A 75Ω

#### Dual 4-channel RF Multiplexers

- 2 GHz bandwidth
- BNC to SMB adapter cables-included

The Agilent 34905A and 34906A RF multiplexers offer broadband switching capabilities for high-frequency and pulsed signals. Use them to route test signals between your device under test and your signal generator, oscilloscope, spectrum analyzer, or other instrumentation.

The RF multiplexers are arranged as two independent 1x4 multiplexers, each with a common shield and a switched center conductor. Connections can be made directly to SMB inputs with 2-GHz usable bandwidth, or to the BNC-to-SMB adapters provided with 1 GHz bandwidth. Multiple banks may be cascaded together for applications requiring even larger topologies—create a stubless 16:1 multiplexer in a single frame.

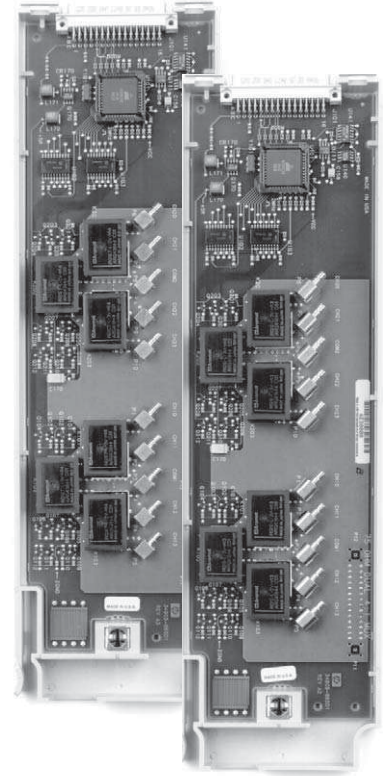
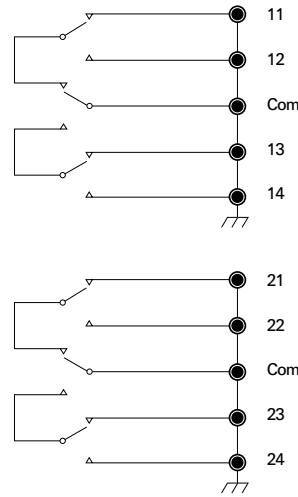

#### 50Ω MUX Typical AC Performance Graphs

Insertion Loss

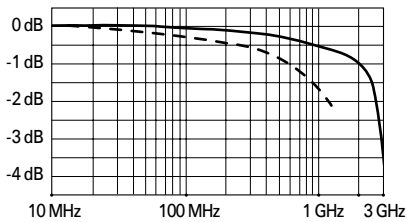

VSWR

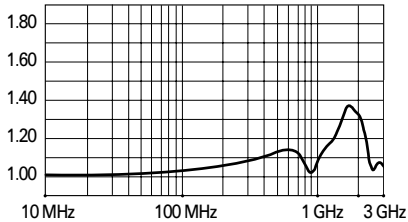

Crosstalk

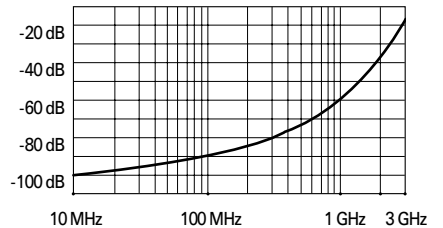

#### 75Ω MUX Typical AC Performance Graphs

Insertion Loss

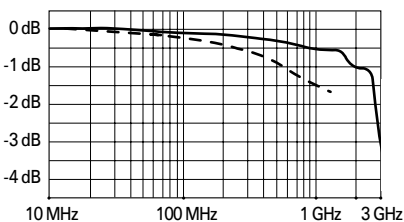

VSWR

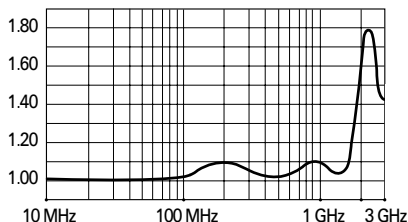

Crosstalk

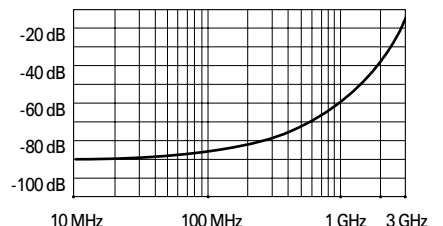

- direct to card
- using provided adapter cables

## 34907A

### Multifunction Module

- 16 bits of digital input and output
- 100 kHz totalizer input
- Two  $\pm 12V$  analog outputs

The Agilent 34907A allows great flexibility for a variety of sense and control applications. It combines two 8-bit ports of digital input and output, a 100 kHz gated totalizer, and two  $\pm 12V$  analog outputs—all on a single earth-referenced module. The digital inputs and totalizer input may be included in a scan. Alarm limits for the digital and event counter inputs are evaluated continuously, capturing and logging alarm conditions even between scans.

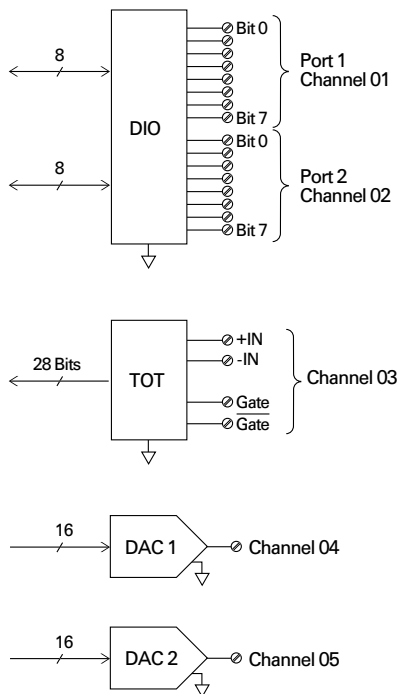

## Digital Input/Output

Use the digital outputs with an external power supply to control microwave switches and attenuators, solenoids, power relays, indicators, and more. Use the digital inputs to sense limit switch and digital bus status. There are no complex handshake modes; reads and writes are initiated either from the front panel or the bus.

### Digital Input/Output

Port 1, 2	8 bit, input or output, nonisolated
Vin(L)	< 0.8V (TTL)
Vin(H)	> 2.0V (TTL)
Vout(L)	< 0.8V @ Iout = -400 mA
Vout(H)	> 2.4V @ Iout = 1 mA
Vin(H) max	< 42V with external open drain pull-up
Alarming	Maskable pattern match or state change
Speed	4 ms (max) alarm sampling
Latency	5 ms (typical) to 34970A alarm output
Read/Write Speed	95/s

## Totalize Input

Count events from devices like photo interrupters, limit-switches, and Hall-effect sensors.

It keeps an updated total which can be read via the front panel or programmatically at any time. With 26 bits of resolution, it can count events at full speed for nearly 11 minutes without an overflow.

### Totalize Input

Max Count	$2^{26} - 1$
Totalize Input	100 kHz (max) Rising or falling edge, programmable
Signal level	1 Vp-p (min) 42 Vpk (max)
Threshold	0V or TTL, jumper selectable
Gate Input	TTL-Hi, TTL-Lo, or none
Count Reset	Manual or Read + Reset
Read Speed	85/s

## Analog Output

Use the two electronically calibrated analog outputs to source bias voltages to your device under test, to control your analog programmable power supplies, or use the outputs as setpoints for your control systems. The outputs are programmed directly in volts, either from the front panel or from the bus.

### Analog Output

DAC 1, 2	$\pm 12V$ , nonisolated
Resolution	1 mV
I <sub>OUT</sub>	10 mA max
Settling time	1 ms to 0.01% of output
Accuracy	$\pm$ (% of output + mV)
1 year $\pm 5^{\circ}C$	0.25% + 20 mV
Temp. Coefficient	$\pm$ ( 0.015% + 1 mV)/ $^{\circ}C$

## Rack Mounting and Dimensions

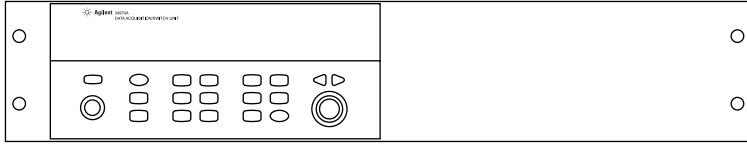

To rack mount a single instrument, order adapter kit 5063-9240 (Option 1CM).

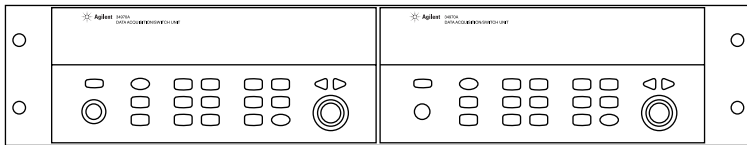

To rack mount two instruments side-by-side, order lock-link kit 5061-9694 and flange kit 5063-9212.

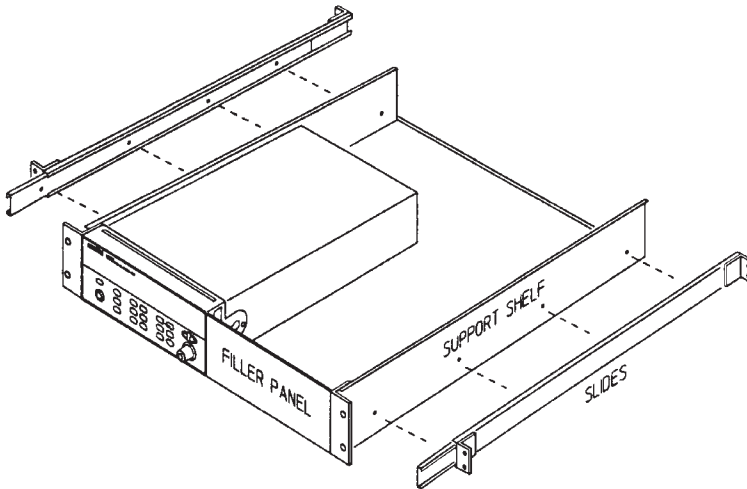

To install one or two instruments in a sliding support shelf, order shelf 5063-9255, and slide kit 1494-0015 (for single instrument, also order filler panel 5002-3999).

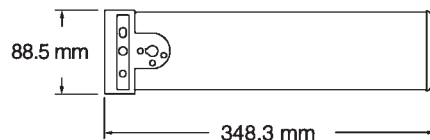
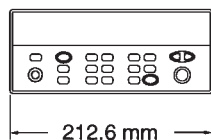
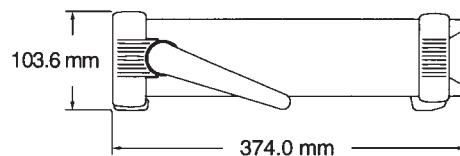
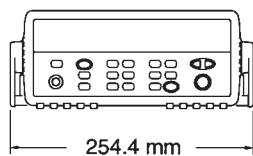

Module

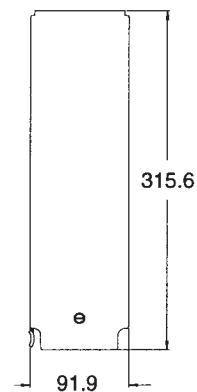



## Ordering Information

### Mainframe

#### 34970A Data Acquisition/Switch Unit

Includes internal 6½ digit DMM, Operating and Service Manuals, Test Report, power cord, and Quick Start package (includes Agilent Benchlink Data Logger II software, RS-232 cable, thermocouple, and screwdriver). Modules are purchased separately and are required to operate.

#### Option 001 Delete Internal DMM

Same as above but deletes DMM and Quick Start package.

Order 34970-80010 to retrofit DMM at a later time.

#### Option 1CM Rack mount kit

#### Option A6J ANSI Z540 compliant calibration

#### Option 0B0 Delete manual set

#### Option AB0 Taiwan: Chinese manual

#### Option AB1 Korea: Korean manual

#### Option AB2 China: Chinese manual

#### Option ABA English: English manual

#### Option ABD Germany: German manual

#### Option ABE Spain: Spanish manual

#### Option ABF France: French manual

#### Option ABJ Japan: Japanese manual

#### Option ABZ Italy: Italian manual

### Modules

#### 34901A 20-Channel armature multiplexer

#### 34902A 16-Channel reed multiplexer

#### 34903A 20-Channel actuator/general purpose switch

#### 34904A 4 x 8 Two-wire matrix switch

#### 34905A Dual 4-Channel RF multiplexer, 50 Ohms

#### 34906A Dual 4-Channel RF multiplexer, 75 Ohms

#### 34907A Multifunction module

#### 34908A 40-Channel single-ended multiplexer

### Accessories

#### 34307A 10-pack of J-type thermocouples

#### 34308A 5-pack of 10 kΩ thermistors

#### 34161A Accessory pouch

#### 34131A Hard carrying case (transit case)

#### E5810A LAN/GPIB gateway

#### 82357A USB/GPIB

#### 34970-80010 DMM field installation kit. Fully calibrated with test report and Quick Start kit

#### 34905-60001 Kit of 10 SMB-to-BNC adapter cables, 50Ω

#### 34906-60001 Kit of 10 SMB-to-BNC adapter cables, 75Ω

### Related Literature

### Pub. number

*Accessories for the 34970A Data Acquisition/Switch Unit*, data sheet 5966-4443EN

*Practical Temperature Measurements*, application note 5965-7822E

*Agilent 34980A Multifunction Switch/Measure*, data sheet 5989-1437EN

Microsoft Windows is a U.S. registered trademark of Microsoft Corporation.

## Agilent Technologies' Test and Measurement Support, Services, and Assistance

Agilent Technologies aims to maximize the value you receive, while minimizing your risk and problems. We strive to ensure that you get the test and measurement capabilities you paid for and obtain the support you need. Our extensive support resources and services can help you choose the right Agilent products for your applications and apply them successfully. Every instrument and system we sell has a global warranty. Two concepts underlie Agilent's overall support policy: "Our Promise" and "Your Advantage."

### Our Promise

Our Promise means your Agilent test and measurement equipment will meet its advertised performance and functionality. When you are choosing new equipment, we will help you with product information, including realistic performance specifications and practical recommendations from experienced test engineers. When you receive your new Agilent equipment, we can help verify that it works properly, and help with initial product operation.

### Your Advantage

Your Advantage means that Agilent offers a wide range of additional expert test and measurement services, which you can purchase according to your unique technical and business needs. Solve problems efficiently and gain a competitive edge by contracting with us for calibration, extra-cost upgrades, out-of-warranty repairs, and onsite education and training, as well as design, system integration, project management, and other professional engineering services. Experienced Agilent engineers and technicians worldwide can help you maximize your productivity, optimize the return on investment of your Agilent instruments and systems, and obtain dependable measurement accuracy for the life of those products.

### Get assistance with all your test and measurement needs at:

[www.agilent.com/find/assist](http://www.agilent.com/find/assist)

**Agilent's IO Libraries Suite** ships with the 34970A to help you quickly establish an error-free connection between your PC and instruments – regardless of the vendor. It provides robust instrument control and works with the software development environment you choose.

### For additional description of Agilent's IO Libraries Suite features and installation requirements, please go to:

[www.agilent.com/find/iosuite-datasheet](http://www.agilent.com/find/iosuite-datasheet)



### Agilent Email Updates

[www.agilent.com/find/emailupdates](http://www.agilent.com/find/emailupdates)

Get the latest information on the products and applications you select.

### Agilent T&M Software and Connectivity

Agilent's Test and Measurement software and connectivity products, solutions and developer network allows you to take time out of connecting your instruments to your computer with tools based on PC standards, so you can focus on your tasks, not on your connections.

Visit [www.agilent.com/find/connectivity](http://www.agilent.com/find/connectivity) for more information.

Product specifications and descriptions in this document subject to change without notice.

© Agilent Technologies, Inc. 1998, 2000, 2004, 2005

Printed in the U.S.A. December 6, 2005

5965-5290EN



Agilent Technologies